

KEY	QTY	PART NUMBER	DRWG. NO.	DESCRIPTION
-----	-----	-------------	-----------	-------------

DETAIL B-B

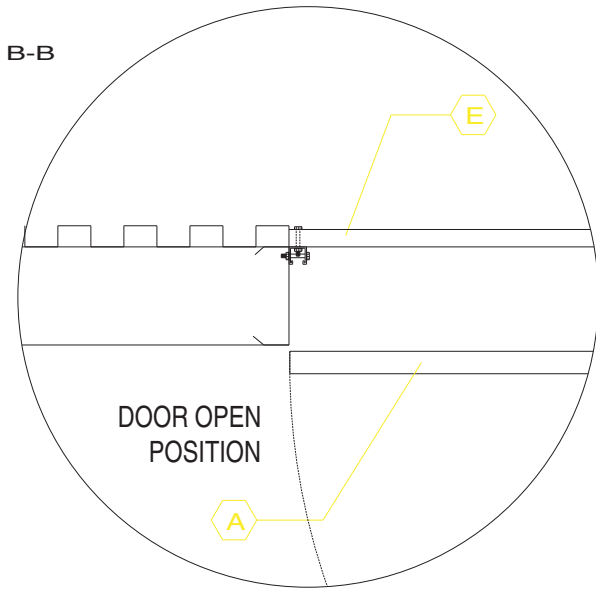

DETAIL C-C

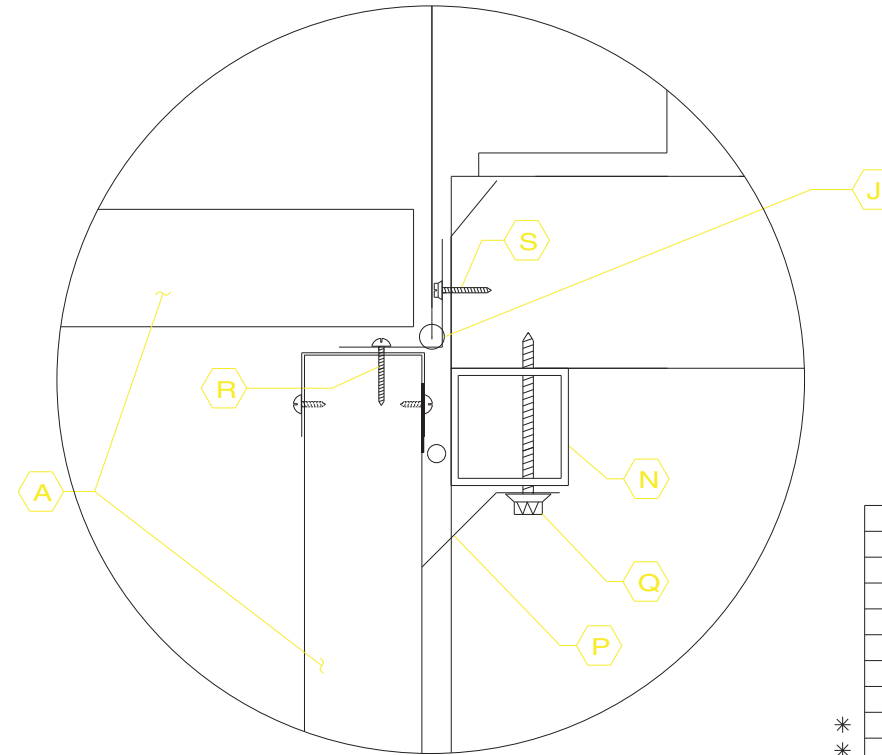

DETAIL A-A

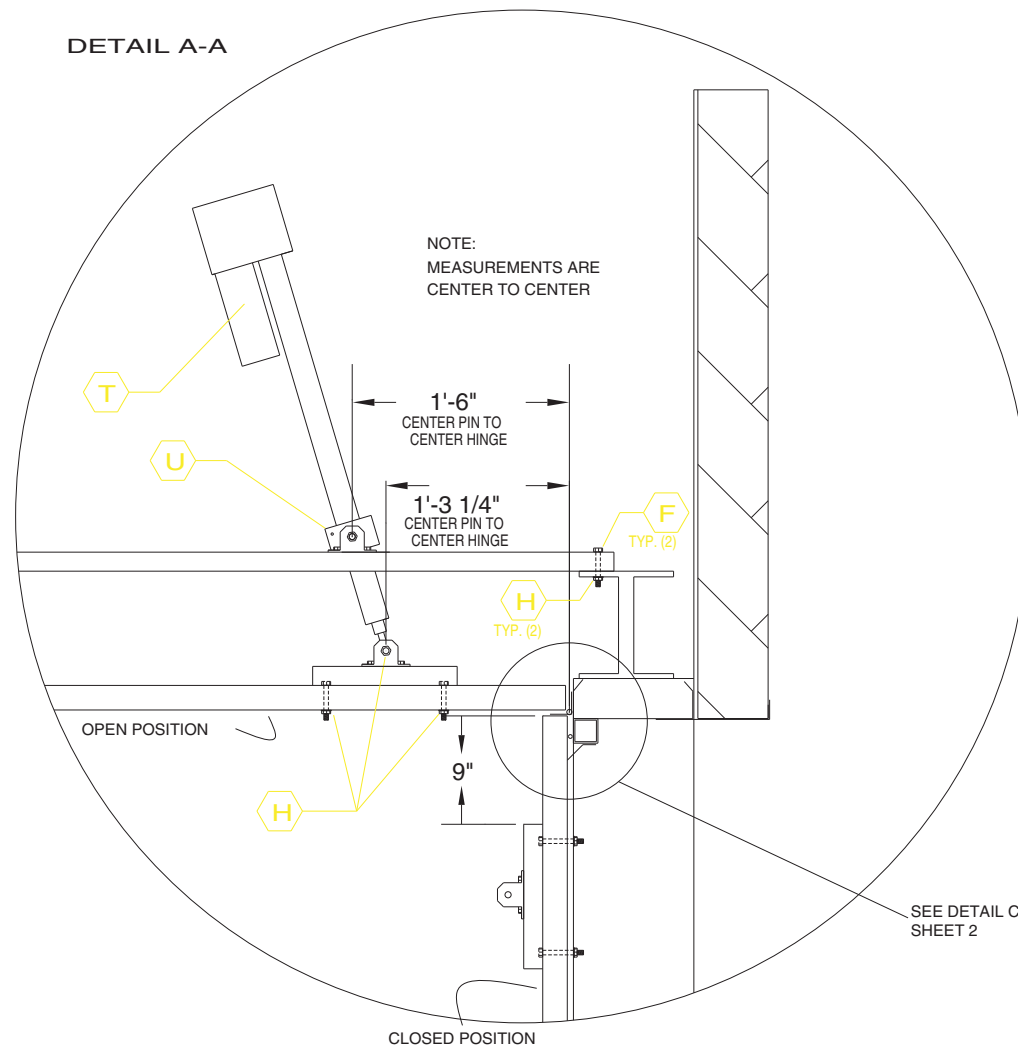

NOTE:

- * QTY. (1) EVERY 8.00" ALONG HINGE.
- NOTE:
- ** SPACED APPROX. 8.00" - 12.00" ALONG PERIMETER OF DOOR SEAL PACKAGE.
- *** MOUNTED AROUND PERIMETER OF ISO-DOOR WALL FRAMING.

KEY	QTY	PART NUMBER	DRWG. NO.	DESCRIPTION	
Y					
X					
W					
V					
U	1	MOTION IND.	9200-448-006	LNTUBE TUBE MOUNT FOR LINEAR ACTUATOR LN24120	
T	1	MOTION IND.	20A8-24	ACTUATOR-LIN 24" 120V, 500 OHM W/O CPCTR	
S	AR	MID-STATE BOLT	12G75UHS	TC1305 HDW-SCREW TEK #12 x 3/4 BONDSEAL ZP	
R	AR	MID-STATE BOLT	TC1304 HDW-SCREW LAG #1/4 x 1-1/4 HWH 18-8 SST	
Q	AR	MID-STATE BOLT	12G300UHS	TC1308 HDW-SCREW TEK #12 x 3 BONDSEAL ZP	
P	2	TECHMARK	PSDOORSEAL ASSY-DOOR SEAL X 10 FEET	
N	AR	AIN PLASTICS	EXTREN 525WUV	TC1311 TUBING-SQ 2 x 2 x .125" EXTREN 525 WUV INHIBITOR	
M					
L	2	MID-STATE BOLT	50C14400RATS	TC1310 HDW-THREADED ROD 1/2-13 x 6" 18-8 SST 50C14400RATS IS 6" = MAKES +/- 11 PCS.	
K					
J	1	BRAUN MFG.	PSHINGE72 HINGE-SST PIANO 3" x 72" NO HOLES	
H	12	FASTENAL	36110	TC1286 HDW-NUT HEX 1/2-13 ZINC PLATED	
G	1	FASTENAL	13214	TC1285 HDW-BOLT HHCS 1/2-13 x 2-3/4 ZINC GR5	
F	8	FASTENAL	13209	TC1283 HDW-BOLT HHCS 1/2-13 x 1-1/2 ZINC GR5	
E	24	FASTENAL	48424	TC1281 HDW-UNI STRUT 1-5/8" x 1-5/8" x 24' 12GA ZINC CUT TO LENGTH	
D					
C	6	FASTENAL	48604	TC1282 HDW-UNI STRUT NUT 1/2-13 x 1-5/8" ZINC	
B	3	LEDEBUHR IND.	PSDOOR ACTUATOR-DOOR BRACKET	
A	1	E.P.S.	ISODOOR ISODOORPANEL "W" x "H"	
SYM	QTY	MFG.	MFG. P/N	TECHMARK P/N	DESCRIPTION / PART NO.

<p>TECHMARK INC. 5801 W. MT. HOPE HWY. LANSING, MI 48917</p>	DRAWING TITLE	
	<p>ACTUATOR TUBE MOUNT DETAIL</p>	

<p>TOLERANCE UNLESS NOTED</p> <p>DECIMAL ± _____</p> <p>HOLE DIA. ± _____</p> <p>ANGLES ± 1%_D</p> <p>MACH. FINISH ✓</p>	<p>WEIGHT</p> <p>SCALE</p> <p>NTS</p> <p>DRAWN DATE</p> <p>RJM 06/16/98</p> <p>CHECKED</p> <p>PROJ ENG</p>	<p>MATERIAL</p> <p>FINISH</p>	<p>SHEET 2</p> <p>OF 2</p>	<p>DRAWING NUMBER</p> <p>B PSDORMT2</p>

REV	NUMBER	DESCRIPTION OF CHANGE	DATE	CK'D
A		RELEASED		